

# LIFEBREATH®

## THE ULTIMATE AIR CLEANER

### Operation and Installation Manual

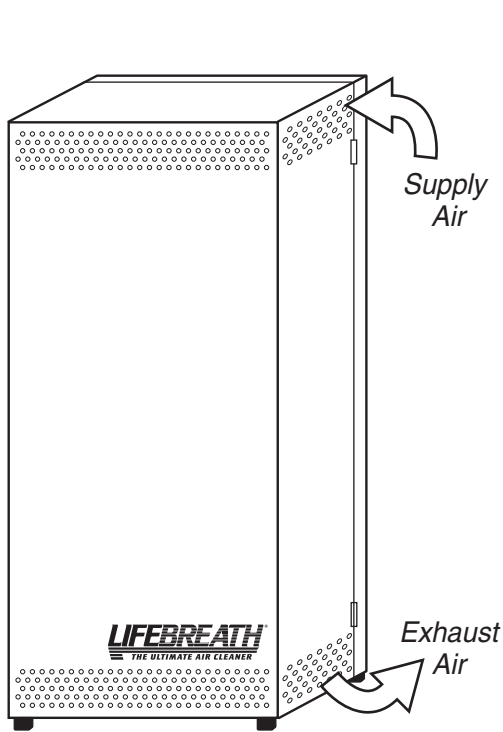

**Console Portable Models**  
TFPC3000 and TFPC3000HEPA

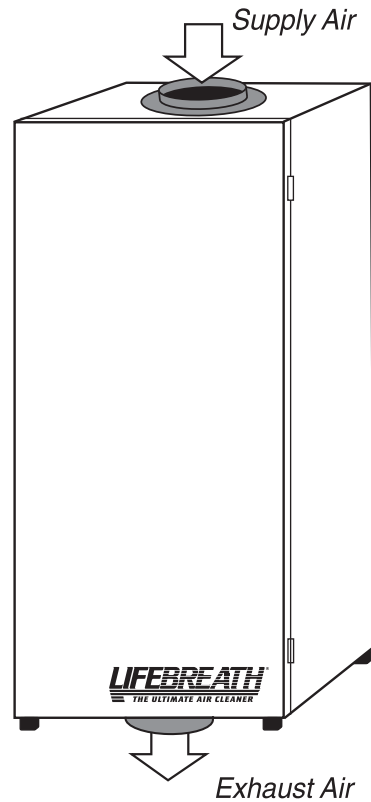

**Whole House Models**  
TFP3000 and TFP3000HEPA

#### Table of Contents

Overview .....	2	Type 1 Installation .....	6-7
TFP Questions & Answers .....	3	Type 2 Installation .....	8
Installation .....	3	Type 3 Installation .....	9-10
Materials Supplied .....	3	Operating Instructions and Annual Check-up .....	11
Preferred Installation Options .....	3	Medical prescription .....	11
Specifications .....	4-5	Wiring Diagram .....	12

### \* LEAVE FOR HOMEOWNER

NOTE: Due to ongoing research and product development, specifications, ratings and dimensions are subject to change without notice.

**Overview**

The Lifebreath TFP Air Cleaner uses "Turbulent Flow Precipitation" to remove the millions of dangerous airborne particles in your home. This technology is based on the Dullien Principle which removes tiny airborne particles which enter the lungs and can cause respiratory problems.

The quiet operating unit has a 2-speed selector switch, along with a high efficiency fan motor, and a foil faced insulated cabinet that is easy to clean.

**The Turbulent Flow Precipitation Principle**

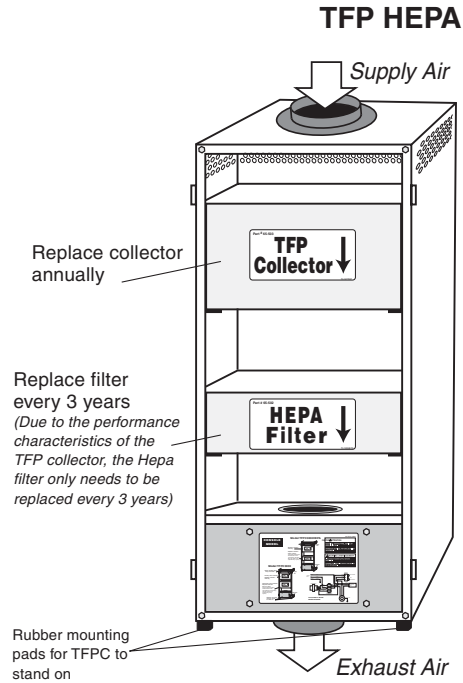
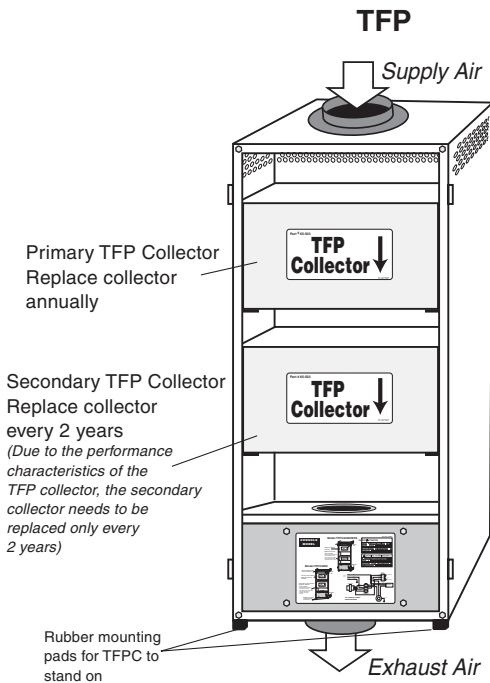
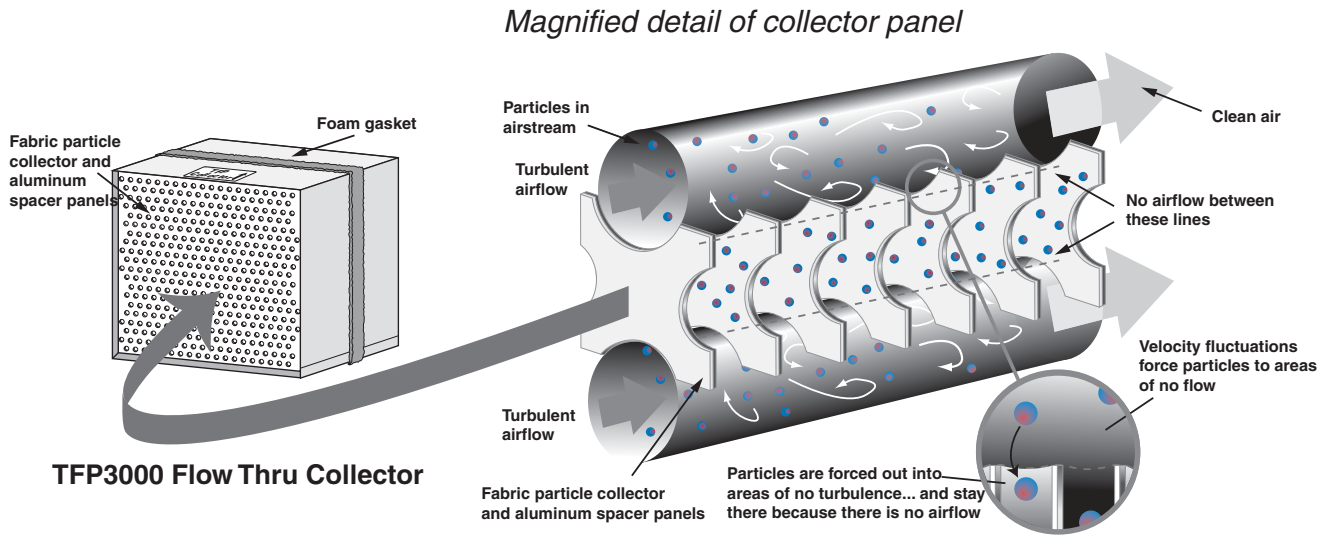

## Overview

TFP (Turbulent Flow Precipitator) Technology removes health threatening particles from the air far more effectively than most other residential cleaners. It operates continuously at maximum efficiency without the need for constant adjustment and cleanout. Unlike some air cleaners, it introduces absolutely no ozone into your home. It cleans the air throughout your home, benefiting all the family, all the time. The TFP allows air to circulate freely, without putting any extra load on your air distribution system.

## TFP Questions & Answers

### Why do I need a TFP Air Cleaner?

The air in today's homes is 3 to 5 times more polluted than outdoor air creating health problems such as asthma, allergies, headaches, and fatigue for the home's occupants. The Lifebreath TFP Air Cleaner will remove 99% of these polluting particles from your home creating a clean and comfortable environment for you and your family.

### Will I notice a difference in the amount of dust in my home?

We have received numerous testimonials from satisfied customers attesting to the significant drop in dust found in the homes where a TFP is installed.

### Does the TFP generate harmful ozone?

The TFP series is an induced airflow system which requires no electric charge.

### Is the TFP a patented unique technology or just another filter?

Nutech Energy Systems hold the patent for this TFP technology. The TFP series are the only one of its kind.

### How much maintenance is involved? How often do the filters need to be replaced?

As tested under average household dust loading, the TFP should be inspected annually. Typically the primary collector should be replaced annually and the secondary collector should be replaced every 2 years.

## Options

Optional Installation Kit: Part# 99-7TFP

Includes:

- two 7" Duct Connection Collars
- 12.5' of 7" Duct
- four Nylon Duct Zip Ties

## Installation

### Location

The TFP should be installed in a conditioned space with easy access for maintenance and an annual check up. A TFP is usually installed in a basement area where air flow noise will be negligible to the occupants.

## Materials Supplied

- 1 TFP
- 4 Mounting Brackets
- 4 Hanging Straps
- 2 Collar Connections
- 4 Port Collar Screws
- 8 Mounting Bracket Screws
- 4 Pieces of Mounting Foam
- 1 Set of Installation/Operating Instructions
- 1 Wiring Diagram
- 1 Warranty Card

## Preferred Installation Options

There are three basic installation options. Select the best method for your needs.

1. TFP to a Forced Air System; use Return/Return Method (horizontal or vertical TFP installation)
2. TFP to a Fully Dedicated HRV System
  - recommended when you wish to clean the incoming air from the HRV
3. Stand Alone System – recommended for homes without forced air systems (ie. radiantly heated homes).

**Specifications**

**TFP3000 and TFPC3000**

**Motors and Blowers**

2 speed, high efficiency PSC Motor - 150 cfm/75 cfm.  
 110 watts - 120 VAC - standard three prong plug to receptacle.  
 The TFP is equipped with a standard power supply on 5'5" (1.6 meters) cable.

**OFF/LOW/HIGH Speed Selector Switch**

Select 75 cfm (Low) or 150 cfm (High).

**Airflow**

150cfm @ .4" WC (High Speed)  
 75 cfm @ .4" WC (Low Speed)

**Collectors**

**Model TFP3000** - Two replaceable TFP collectors  
**Model TFPC3000 CONSOLE** - Two replaceable TFP collectors  
 • Easy to remove for cleaning and replacement  
 • Annual inspection recommended

**Case**

Twenty gauge prepainted galvanized steel (G60) for superior corrosion resistance

**Weight**

55 lbs. (24.4 Kgs)

**Electrical Codes**

Conforms to CSA and UL standards

**Mounting the Wholehouse TFP - very flexible**

- Mount to the furnace return
- Mount between the HRV and the furnace
- Hang from a joist and duct to the furnace
- Stand alone installation

**Warranty**

Units carry a five year warranty on all replacement parts except the collectors/filters.

**Options**

- 65-503R - One replacement TFP Collector
- 65-502R - One replacement HEPA filter

**Optional Installation Kit: Part # 99-TFP**

- Includes - two 7" Duct Connection Collars
- 12.5' of 7" Non-insulated Flex Duct
- four Nylon Duct Zip Ties

**Console Portable  
 Model TFPC3000**

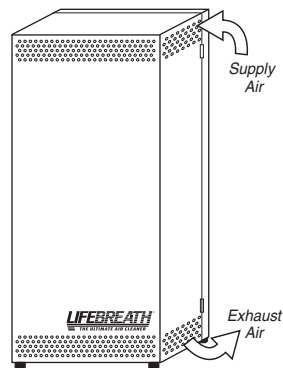

**TFP3000**

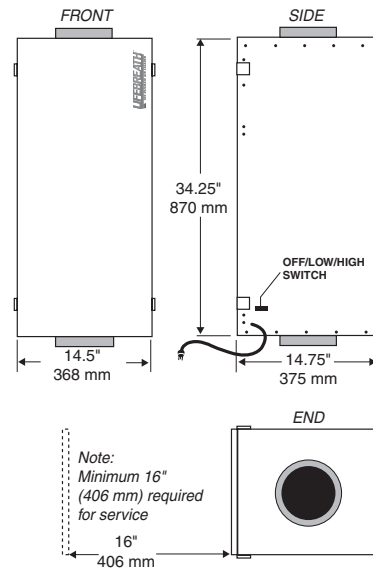

All duct connections are 7" (178 mm)

**Model TFP 3000 & TFPC3000 Particle Capture Rate**

Particle Size (microns)	Percentage Caught
5 or more	99%
2 - 3	97%
1	95%
0.5 - 0.9	90%

- A human hair is 100 microns wide.
- Spores and pollen are all larger than 8 microns.
- A micron is 1/1000 of a millimetre, or less than 1/2 of 1/10,000 of an inch.

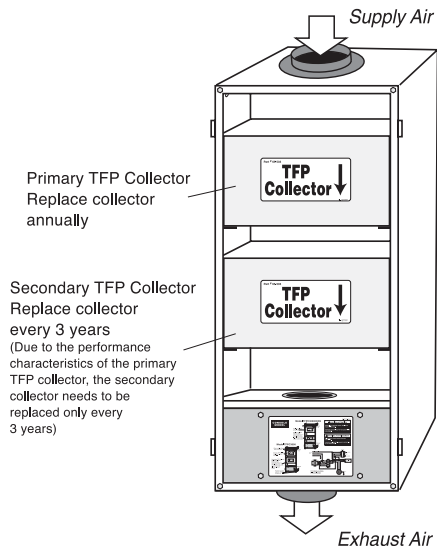

Date: \_\_\_\_\_  
 Tag: \_\_\_\_\_ Qty: \_\_\_\_\_  
 Project: \_\_\_\_\_  
 Engineer: \_\_\_\_\_

Contractor: \_\_\_\_\_  
 Supplier: \_\_\_\_\_  
 Quote#: \_\_\_\_\_  
 Submitted by: \_\_\_\_\_



511 McCormick Blvd.  
 London, Ontario N5W 4C8  
 T (519) 457-1904  
 F (519) 457-1676  
 Email: nutech@lifebreath.com

270 Regency Ridge, Suite 210  
 Dayton, Ohio 45459  
 T (937) 439-6676  
 F (937) 439-6685  
 Website: www.lifebreath.com



**Specifications**

**TFP3000HEPA and TFPC3000HEPA**

**Motors and Blowers**

2 speed, high efficiency PSC Motor - 150 cfm/75 cfm.  
 110 watts - 120 VAC - standard three prong plug to receptacle.  
 The TFP is equipped with a standard power supply on 5'5" (1.6 meters) cable.

**OFF/LOW/HIGH Speed Selector Switch**

Select 75 cfm (Low) or 150 cfm (High).

**Airflow**

150cfm @ .4" WC (High Speed)  
 75 cfm @ .4" WC (Low Speed)

**Collectors**

**Model TFP3000** - One replaceable TFP collector and one replaceable HEPA filter

**Model TFPC3000HEPA CONSOLE** - One replaceable TFP collector and one replaceable HEPA filter

- Easy to remove for cleaning and replacement
- Annual inspection recommended

**Case**

Twenty gauge prepainted galvanized steel (G60) for superior corrosion resistance

**Weight**

55 lbs. (24.4 Kgs)

**Electrical Codes**

Conforms to CSA and UL standards

**Mounting the Wholehouse TFP - very flexible**

- Mount to the furnace return
- Mount between the HRV and the furnace
- Hang from a joist and duct to the furnace
- Stand alone installation

**Warranty**

Units carry a five year warranty on all replacement parts except the collectors/filters.

**Options**

- 65-503R - One replacement TFP Collector
- 65-502R - One replacement HEPA filter

**Optional Installation Kit: Part # 99-TFP**

- Includes - two 7" Duct Connection Collars
- 12.5' of 7" Non-insulated Flex Duct
- four Nylon Duct Zip Ties

**Console Portable Model TFPC3000HEPA**

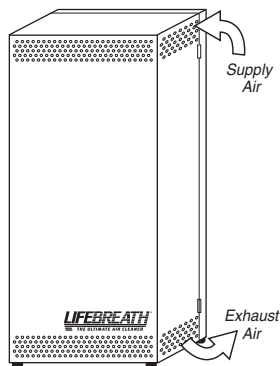

**TFP3000HEPA**

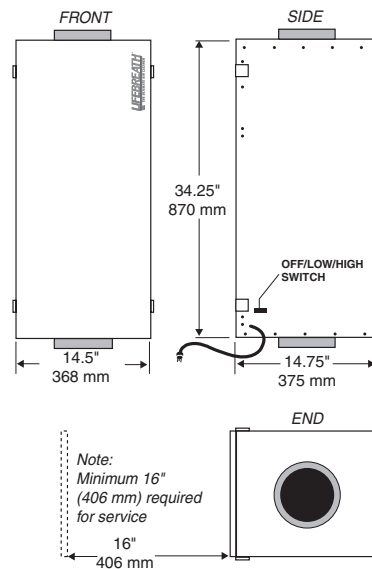

All duct connections are 7" (178 mm)

**Model TFP3000HEPA & TFPC3000HEPA Particle Capture Rate**

Particle Size (microns)	Percentage Caught
.3 or more	99.7%

- Model TFP3000HEPA - 99.97% efficient at .3 microns.
- A human hair is 100 microns wide.
- Spores and pollen are all larger than 8 microns.
- A micron is 1/1000 of a millimetre, or less than 1/2 of 1/10,000 of an inch.

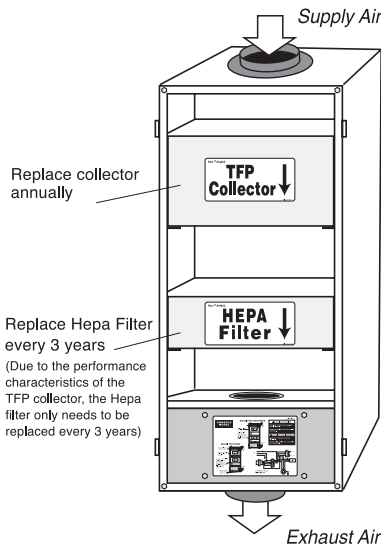

Date: \_\_\_\_\_

Tag: \_\_\_\_\_ Qty: \_\_\_\_\_

Project: \_\_\_\_\_

Engineer: \_\_\_\_\_

Contractor: \_\_\_\_\_

Supplier: \_\_\_\_\_

Quote#: \_\_\_\_\_

Submitted by: \_\_\_\_\_



511 McCormick Blvd.  
 London, Ontario N5W 4C8  
 T (519) 457-1904  
 F (519) 457-1676  
 Email: nutech@lifebreath.com

270 Regency Ridge, Suite 210  
 Dayton, Ohio 45459  
 T (937) 439-6676  
 F (937) 439-6685  
 Website: www.lifebreath.com



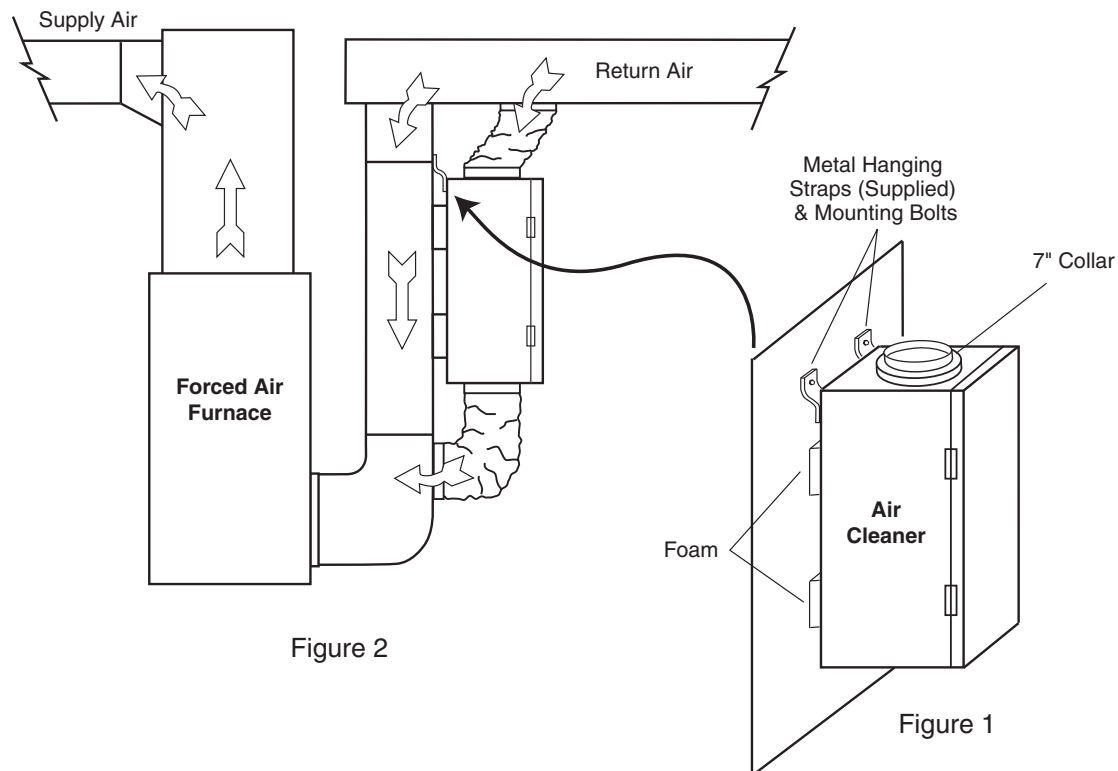

Figure 2

Figure 1

### TFP Directly Connected to Forced Air Heating System

1. Install 7" collar (provided) on top and bottom of TFP (Fig. 1). Use (4) 8/32" X 3/8" screws (provided).
2. Remove protective backing from pieces of foam and stick them to the 4 corners of the TFP on the side being mounted against the plenum.
3. Remove the 4 mounting bolts from the back of the TFP cabinet. (Fig. 1)
4. Attach top and bottom mounting brackets (provided) vertical to the TFP cabinet and reinstall mounting bolts.
5. Lift the TFP into position. Edge of TFP must be positioned on plenum to allow clearance needed for latches.
6. Install the (4) 8/32" X 3/4" mounting screws (provided) through the brackets and into position. Tighten and secure.
7. TFP should now sit securely against the plenum with the foam in between.
8. Cut 2 - 7" holes in the return air plenum. Install ducting to join TFP to the return air plenum (Fig. 2).

**NOTE:** Do not support the weight of the TFP on the duct. Duct must be open and not pinched.

**NOTE:** Due to possible noise transfer through the duct system, it may be preferable in some situations to hang the TFP a short distance from the plenum, and connect by running flexible ducting between them. Four nylon hanging straps are provided for this option.

### ATTENTION

**The furnace fan and/or HRV must operate continuously for Type 1 and Type 2 installations. If they do not operate continuously, then interlocking them electrically with the TFP is acceptable. Consult a certified electrician.**

**TYPE 1 INSTALLATION - Option B**

**Horizontal Design**

Use Option B when Option A is not practical.

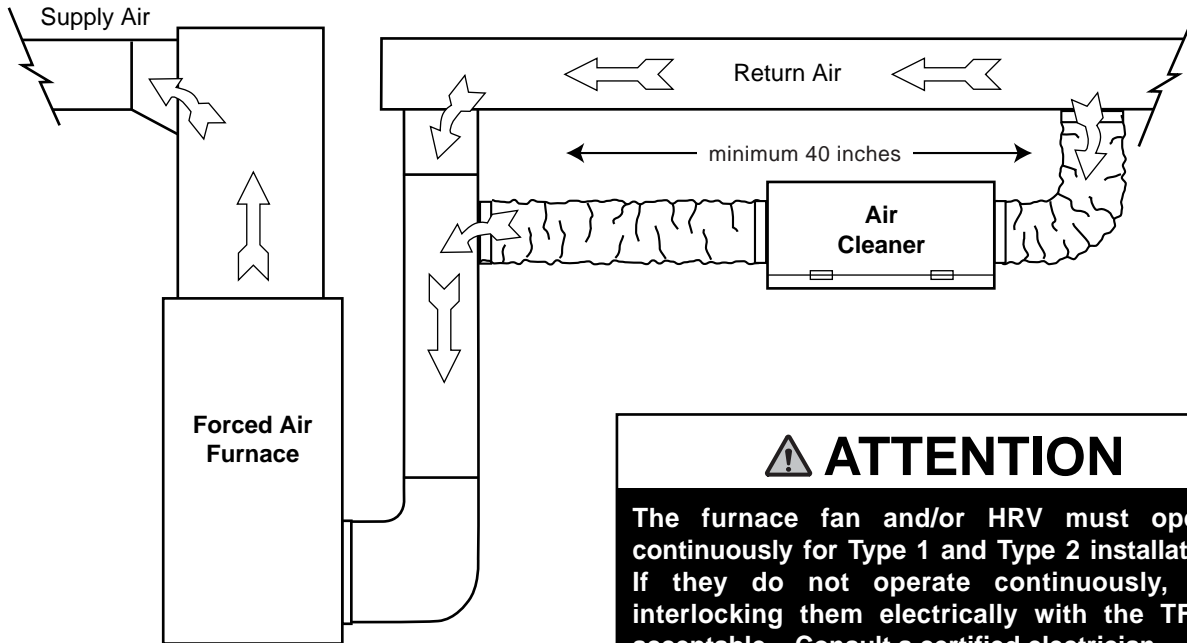

**⚠ ATTENTION**  
The furnace fan and/or HRV must operate continuously for Type 1 and Type 2 installations. If they do not operate continuously, then interlocking them electrically with the TFP is acceptable. Consult a certified electrician.

**TYPE 1 INSTALLATION - Option C**

**Vertical Design**

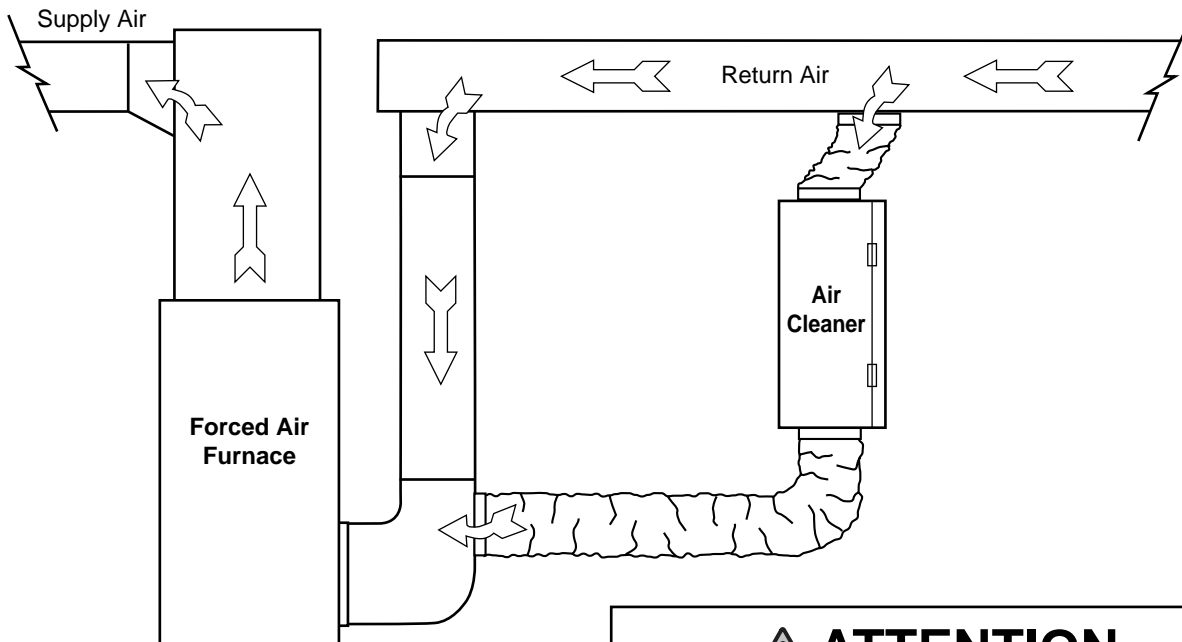

Use Option C when Option A is not practical.

**⚠ ATTENTION**  
The furnace fan and/or HRV must operate continuously for Type 1 and Type 2 installations. If they do not operate continuously, then interlocking them electrically with the TFP is acceptable. Consult a certified electrician.

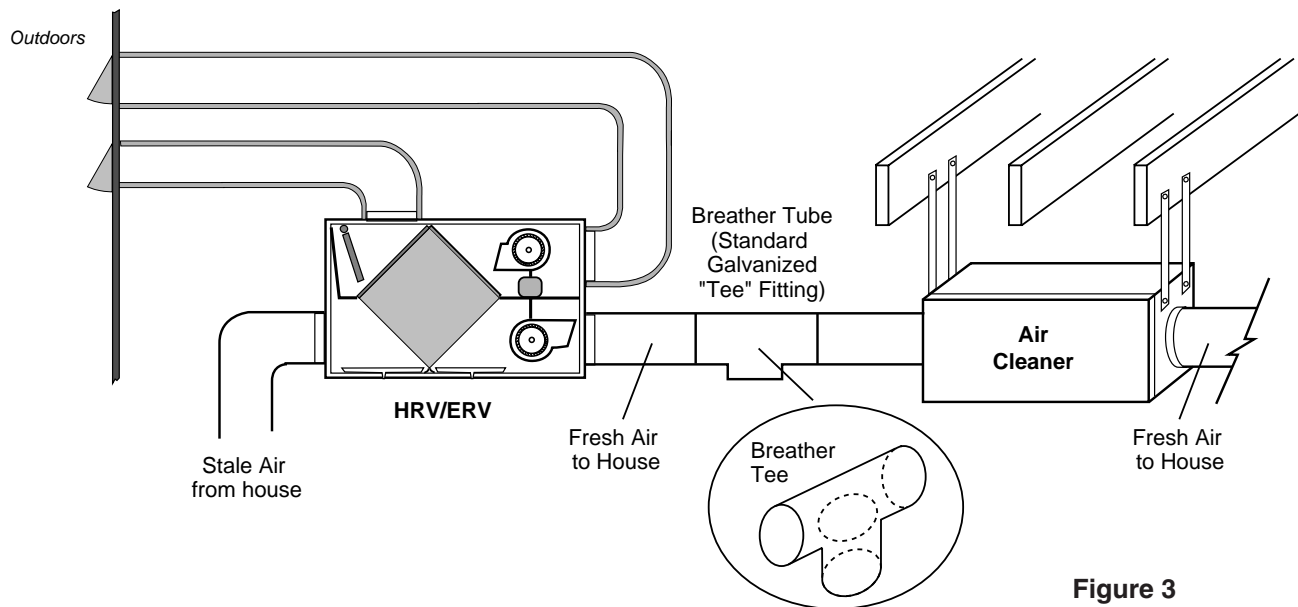

Figure 3

### TFP Connected to Heat Recovery Ventilator Location

The TFP should be located in the main trunk of the fresh air to house line, after the Heat Recovery Ventilator (HRV) and before any branch lines. (Fig. 3)

### Mounting

1. Locate mounting bolts (4) on side of TFP cabinet for vertical hanging (Fig. 3) and remove.
2. Measure distance between the bolts and mark it on the floor/header joist where the TFP is to be hung.
3. Fasten hanging straps to floor joists using wide head nails or screws with washers.
4. Insert hanging bolts through prepunched holes in straps and lift TFP into position. Tighten and secure bolts.

### Ducting

1. Install (2) 7" collars (provided) on TFP cabinet with (8) 8/32" X 3/8" sheet metal screws provided.
2. The ducting between the TFP and the HRV, and between the TFP and the main supply trunk line to the house, should be kept as straight as possible.

3. A relief opening or breathing T is required to prevent pressure differences.
4. A short piece (1-2 foot) of flexible ducting should be used on both sides of the TFP (Fig. 3). This will reduce vibration and noise transfer if present.

**NOTE: Please refer to the HRV installation manual for proper ducting of that appliance.**

### Breathing T

The "Breathing T" is designed to assist in neutralizing pressure differences which can occur between the HRV and the TFP when joined together. The "Breathing T" should be situated in an area with suitable indoor air quality (IAQ). Avoid mechanical rooms and workshops. If required, an external connection should be made from the "Breathing T" to an area with suitable IAQ (the air should be free of fumes, vapors, odors, or large airborne particles etc.).

## ⚠ CAUTION

The room in which the breathing T is open should be free of combustion equipment such as gas hot water tanks and furnaces. If the T must be exposed in these areas, a pressure test (spillage or backdraft test) should be conducted on the combustion equipment after everything is installed.

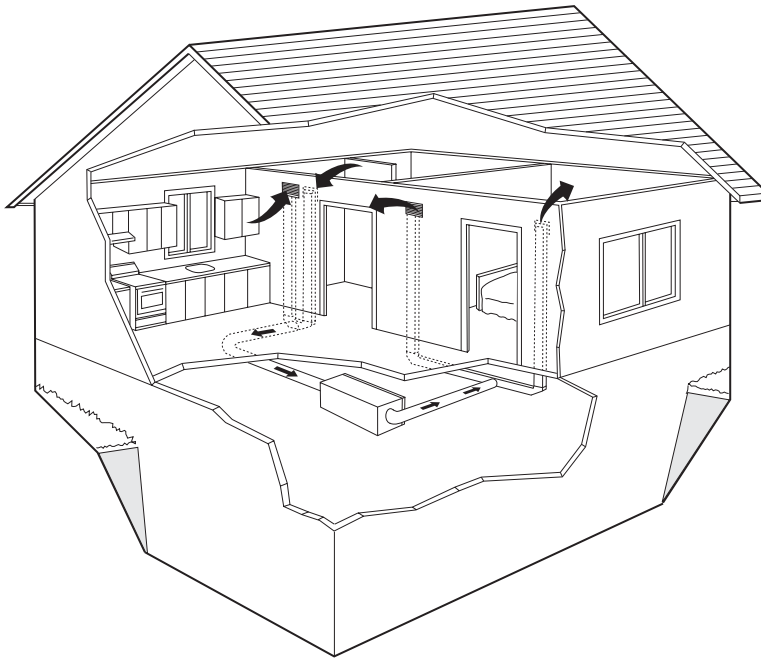

Figure 4

This installation configuration is recommended for homes without forced air systems (i.e. radiantly heated homes). The duct should be sized and designed to achieve a sweeping action from one end of the home to the other. Considerations may include strategic clean air placement for allergy or asthma sufferers.

Suggested Air Cleaner locations:

- Mechanical Room
- Attic (*Extra consideration is required to ensure heat loss through duct work is minimized*)
- Closet

### TFP Independent Installation No HRV, Radiant Heating System

#### Location

1. A TFP is usually installed in a basement area where air flow noise will be negligible to the occupants.
2. A central location between the clean air supply grille and return grille is recommended.

#### Mounting

Refer to "Mounting" under Type 2 Installations.

#### Ducting

1. Install (2) 7" collars (provided) on TFP cabinet with (8) 8/32" X 3/8" sheet metal screws provided (Fig.4).
2. Ducting will usually consist of one return with grille from one side of the home, and one supply with grille at the opposite end of the home (Fig. 4).
3. Ductwork should be no smaller than the size of the port collars (7") on the TFP.
4. Ductwork should be kept as short and straight as possible to allow for good air circulation.

**Note: For installations of more than one return or supply (greater than .5 e.s.p.), it is often necessary to add an inline fan to the system as a booster.**

**Office or Classroom Application**

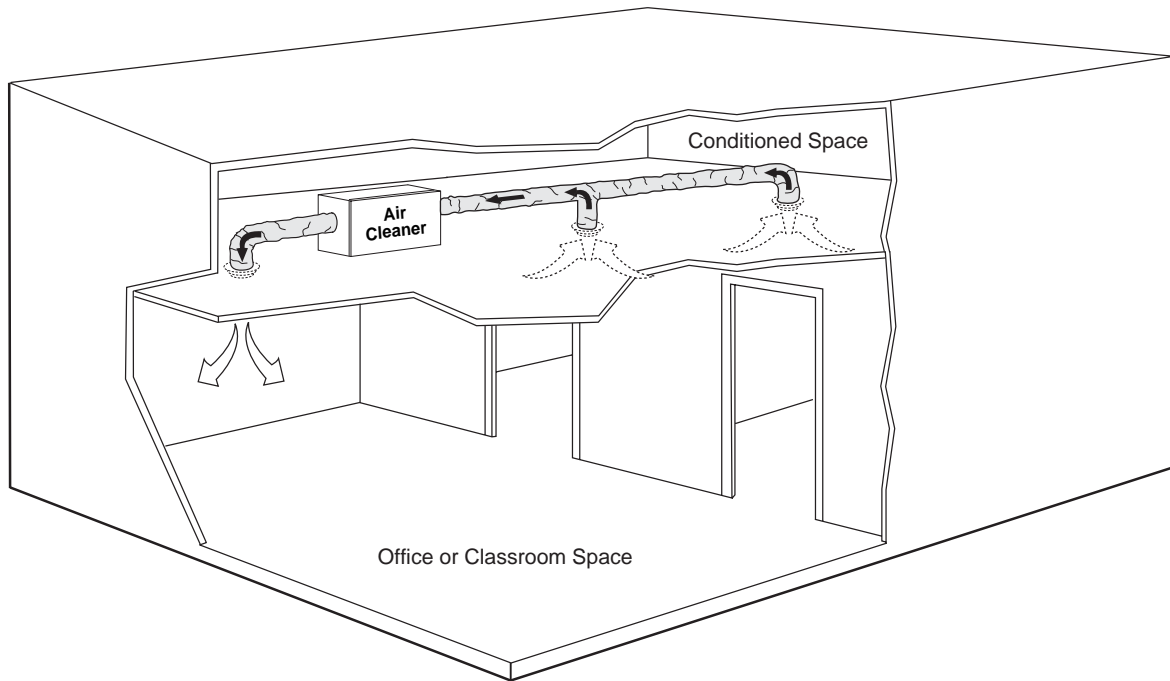

**Work Table Application**

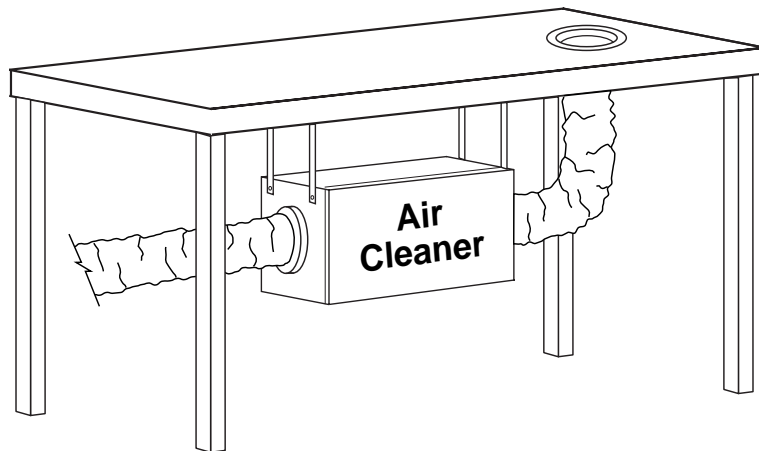

## Operating Instructions and Annual Check-up

### Operating Instructions

It is recommended the unit run continuously to provide the full benefits of particulate removal. Use the OFF/LOW/HIGH speed selection switch to select high (150cfm) or low (75(cfm) speed.

### Maintenance

Annual inspection is recommended for cleaning and replacement of the Collectors/HEPA filter. Discard and replace the collectors when required. Normally the primary collector is replaced annually and the secondary collector is replaced every 2 years.

As each home has differences of size, occupancy, location, infiltration rates and homeowner needs, it is hard to estimate when the collectors will need to be changed.

The collectors will slide out. Some discolouration of the collector medium can be expected and when loose dust falls from the collector, it is time to replace it. Turn off the TFP, furnace fan and HRV. Open the door and slide out the collectors to check buildup

and do an annual inspection of overall unit. Before replacing any collectors, vacuum any dust inside the cabinet or surrounding area. When replacing the collectors, make sure the directional arrows are noted and the collectors are installed correctly. Close the door and restart TFP, furnace and HRV fan.

When your TFP is installed with a forced air heating system you are still required to use the recommended furnace filter. This may be a good time to inspect this filter as well.

When new collectors are required, call your dealer.

Model TFP3000 - Two replaceable TFP collectors

Model TFP3000HEPA - 1 TFP Collector, 1 HEPA filter

## CAUTION

**Disconnect all power sources before attempting any service.**

## Medical Prescription

# R<sub>x</sub>

## Prescription

for  
Health Care Product

---

PATIENT NAME

---

ADDRESS

---

Your doctor has prescribed the use of an Air Cleaner to aid in the relief of your medical condition.  
For allowable tax deduction or insurance purposes, please retain a completed copy of this form for your records.

---

PHYSICIAN NAME

---

ADDRESS

---

PHYSICIAN SIGNATURE

TFP-03

# R<sub>x</sub>

## Prescription

for  
Health Care Product

---

PATIENT NAME

---

ADDRESS

---

Your doctor has prescribed the use of an Air Cleaner to aid in the relief of your medical condition.  
For allowable tax deduction or insurance purposes, please retain a completed copy of this form for your records.

---

PHYSICIAN NAME

---

ADDRESS

---

PHYSICIAN SIGNATURE

TFP-03

The TFP may qualify for an insurance and/or a medical tax deduction with a physician's prescription.

# Wiring Diagram

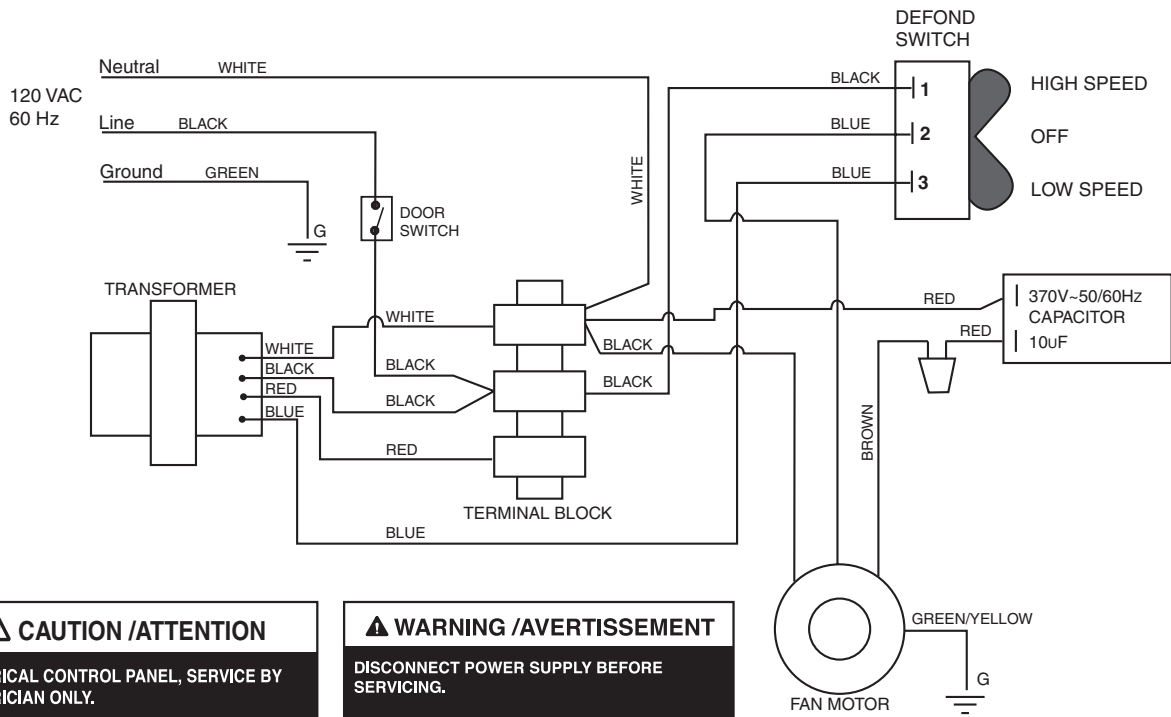

## ⚠ CAUTION / ATTENTION

ELECTRICAL CONTROL PANEL, SERVICE BY  
ELECTRICIAN ONLY.

PANNEAU ÉLECTRIQUE, PAR UN ÉLECTRICIEN  
SEULEMENT.

## ⚠ WARNING / AVERTISSEMENT

DISCONNECT POWER SUPPLY BEFORE  
SERVICING.

COUPER L'ALIMENTATION AVANT L'ENTRETIEN  
ET LE DÉPANNAGE.